

## Testing Teccor Semiconductor Devices Using Curve Tracers

---

### Introduction

---

One of the most useful and versatile instruments for testing semiconductor devices is the curve tracer (CT). The best known manufacturer of curve tracers is TEKTRONIX, which produces four basic models: the 575, 576, 577 and 370. These instruments are specially adapted CRT display screens with associated electronics such as power supplies, amplifiers, and variable input and output functions that allow the user to display the operating characteristics of a device in an easy-to-read, standard graph form. Operation of TEKTRONIX CTs is simple and straightforward and easily taught to non-technical personnel. Although widely used by semiconductor manufacturers for design and analytical work, the device consumer will find many uses for the curve tracer such as incoming quality control, failure analysis, and supplier comparison. Curve tracers may be easily adapted for go-no go production testing. TEKTRONIX also supplies optional accessories for specific applications along with other useful hardware.

### TEKTRONIX Equipment

---

TEKTRONIX produces four curve tracer models: the 575, 576, 577 and 370. The 575 is no longer in production; however, many units are still operating in the field and it is still an extremely useful instrument. The 576, 577 and 370 are current models and are more streamlined in their appearance and operation. The 577 is a less elaborate version of the 576, yet retains all necessary test functions.

The following basic functions are common to all curve tracers:

- Power Supply—supplies positive DC voltage, negative DC voltage, or AC voltage to bias the device. Available power is varied by limiting resistors.
- Step Generator—supplies current or voltage in precise steps to control the electrode of the device. The number, polarity and frequency of steps are selectable.
- Horizontal Amplifier—displays power supply voltage as applied to the device. Scale calibration is selectable.
- Vertical Amplifier—displays current drawn from the supply by the device. Scale calibration is selectable.

Also present are controls for beam position, calibration, pulse operation, and others that vary from model to model. The basic theory of operation is that for each curve one terminal is driven with a constant voltage or current and the other one is swept with a half sinewave of voltage. The driving voltage is stepped through several values and a different trace is drawn on each sweep to generate a family of curves.

### Limitations, Accuracy, and Correlation

---

Although the curve tracer is a highly versatile device, it is not capable of every test that one may wish to perform on semiconductor devices such as  $dv/dt$ , secondary reverse breakdown,

switching speeds, and others. Also, tests at very high currents and/or voltages are difficult to make accurately and avoid damaging the devices. A special high current test fixture available from TEKTRONIX can extend operation to 200A pulsed peak. Kelvin contacts available on the 576 and 577 eliminate inaccuracy in voltage measured at high current ( $V_{TM}$ ) by sensing voltage drop due to contact resistance and subtracting from the reading.

Accuracy of the unit is within the published manufacturer's specification. The curve tracer should be allowed to warm-up and stabilize before testing begins. Always expand the horizontal or vertical scale as far as possible to increase the resolution. Be judicious in recording data from the screen, as the trace line width and scale resolution factor somewhat limit the accuracy of what may be read. Regular calibration checks of the instrument are recommended. Some users keep a selection of calibrated devices on hand to verify instrument operation when in doubt. Re-calibration or adjustment should be performed only by qualified personnel.

*Often discrepancies exist between measurements taken on different types of instrument.* In particular, most semiconductor manufacturers use high-speed, computerized test equipment to test devices. They test using very short pulses. If a borderline unit is then measured on a curve tracer, it may appear to be out of specification. The most common culprit here is heat. When a semiconductor device increases in temperature due to current flow, certain characteristics may change, notably gate characteristics on SCRs, gain on transistors, leakage, etc. It is very difficult to operate the curve tracer in such a way as to eliminate the heating effect. Pulsed or single trace operation will help to reduce this problem, but care should be taken in comparing curve tracer measurements to computer tests. Other factors which may create differences are stray capacitances, impedance matching, noise, and device oscillation.

The following test procedures have been written with the use of the model 576 curve tracer in mind. An appendix follows to describe the minor changes that are required to use the model 577 curve tracer. The standard 575 model lacks AC mode, voltage greater than 200V, pulse operations, DC mode, and step offset controls. The 575 MOD122C does allow voltage up to 400V, including 1500V in an AC mode.

It must be remembered that the 575 was designed at the time only to test transistors and diodes. Some ingenuity, experience, and external hardware may be required to test other types of devices.

For further information or assistance in device testing on TEKTRONIX curve tracers, contact the Teccor Applications Engineering group.

### Safety (Cautions and Warnings)

---

The TEKTRONIX safety rules supplied with each curve tracer should be adhered to rigidly. No attempt should be made to defeat any of the safety interlocks on the device as the curve tracer can produce a lethal shock. Also older 575 models do not

have the safety interlocks as do the new models. Care should be taken to never touch any device or open the terminal while energized.

**WARNING: Devices may be easily damaged on the curve tracer from electrical overstress.**

Follow these rules to avoid destroying devices:

- Familiarize yourself with the expected maximum limits of the device.
- Limit the current with the variable resistor to the minimum necessary to conduct the test.
- Increase power slowly to the specified limit.
- Watch for device “runaway” due to heating.
- Apply and increase gate or base drive slowly and in small steps.
- Conduct tests in the minimum time required.

## General Test Procedures

Read all manuals before operating a curve tracer.

Perform the following manufacturer’s equipment check:

1. Turn on and warm up curve tracer, but turn off, or down, all power supplies.
2. Correctly identify terminals of the device to be tested. Consult the manufacturer’s guide if necessary.
3. Insert the device into the test fixture, matching the device and test terminals.
4. Remove hands from the device and/or close interlock cover.
5. Apply required bias and/or drive.
6. Record results as required.
7. Disconnect all power to the device before removing.

## Power Rectifiers

The rectifier is a unidirectional device which conducts when forward voltage (above 0.7 volts) is applied.

To connect the rectifier:

1. Connect *Anode* to *Collector Terminal (C)*.
2. Connect *Cathode* to *Emitter Terminal (E)*.

To begin testing, perform the following procedures.

### Procedure 1: $V_{RRM}$ and $I_{RM}$

To measure the  $V_{RRM}$  and  $I_{RM}$  parameter:

1. Set *Collector Voltage Supply Range* to *1500 volts*.
2. Set *Horizontal* knob to sufficient scale to allow viewing of trace at the required voltage level (100 volts/DIV for 400 & 600 volt devices and 50 volts/DIV for 200 volt devices).
3. Set *Mode* to *Leakage*.
4. Set *Vertical* knob to *100 microamps/DIV*. (Due to leakage setting, the CRT readout will be 100nA per division.)
5. Set *Terminal Selector* to *Emitter Grounded-Open Base*.
6. Set *Polarity* to *(-)*.
7. Set *Power Dissipation* to *2.2 watts*.

8. Set *Left-Right Terminal Jack Selector* to correspond with location of test fixture.
9. Increase *Variable Collector Supply Voltage* to the rated  $V_{RRM}$  of the device and observe the dot on the CRT. Read across horizontally from the dot to the vertical current scale. This measured value will be the leakage current. (See Figure 19.1.)

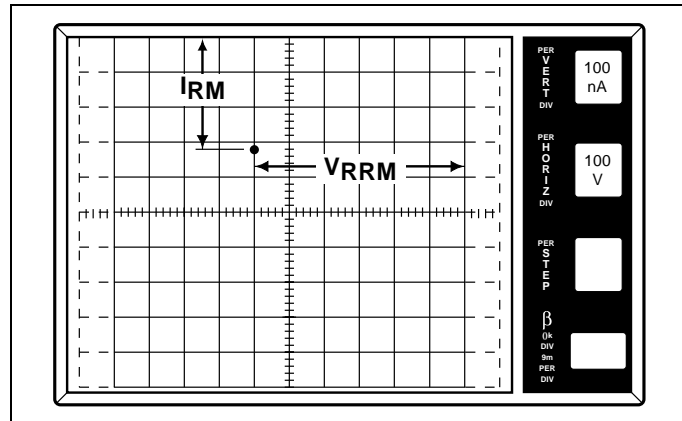

Figure 19.1  $I_{RM}$  is equal to 340nA at  $V_{RRM}$  equal to 600

### Procedure 2: $V_{FM}$

Before testing, note the following:

- A Kelvin test fixture is required for this test. If a Kelvin fixture is not used, an error in measurement of  $V_{FM}$  will result due to voltage drop in fixture. If a Kelvin fixture is not available, see the attached instructions for necessary information to wire a test fixture with Kelvin connections.
- Due to the current limitations of standard curve tracer model 576,  $V_{FM}$  cannot be tested at rated current without a TEKTRONIX model 176 high-current module. The procedure below is done at  $I_{T(RMS)} = 10$  amps (20 APK). This test parameter will allow the use of a standard curve tracer and still provide an estimate of whether  $V_{FM}$  is within spec.

To measure the  $V_{FM}$  parameter:

1. Set *Collector Voltage Supply Range* to *15 Max Peak volts*.
2. Set *Horizontal* knob to *0.5 volts/DIV*.
3. Set *Mode* to *Norm*.
4. Set *Vertical* knob to *2 amps/DIV*.
5. Set *Power Dissipation* to *220 watts* (100 watts on 577).
6. Set *Polarity* to *(+)*.
7. Set *Left-Right Terminal Jack Selector* to correspond with location of test fixture.
8. Increase *Variable Collector Supply Voltage* until current reaches 20 amps.

**WARNING: Limit test time to 15 seconds maximum.**

To measure  $V_{FM}$ , follow along horizontal scale to the point where the trace crosses the 20 amp axis. The distance from the left-hand side of scale to the crossing point is the  $V_{FM}$  value (See Figure 19.2).

# Testing Teccor Semiconductor Devices Using Curve Tracers

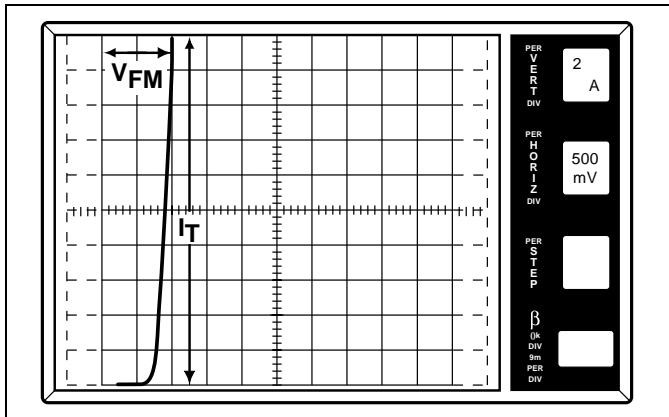

Figure 19.2  $V_{FM}$  is equal to 1.0 volt at  $I_{PK}$  is equal to 20

## SCRs

SCRs are half-wave unidirectional rectifiers which are turned on when current is supplied to the gate terminal. If the current supplied to the gate is to be in the range of 12-500 microamps, then a sensitive SCR is required; if the gate current is between 1 milliamp and 50 milliamps, then a non-sensitive SCR is required.

To connect the rectifier:

1. Connect *Anode* to *Collector Terminal (C)*.
2. Connect *Cathode* to *Emitter Terminal (E)*.

Note: When sensitive SCR's are being tested, a 1K resistor must be connected between the gate and the cathode, except when testing  $I_{GT}$ .

To begin testing, perform the following procedures.

### Procedure 1: $V_{DRM}$ , $V_{RRM}$ , $I_{DRM}$ , $I_{RRM}$

To measure the  $V_{DRM}$ ,  $V_{RRM}$ ,  $I_{DRM}$ , and  $I_{RRM}$  parameter:

1. Set *Collector Voltage Supply Range* to appropriate *Max Peak Volts* for device under test. (Value selected should be equal to or greater than the device's  $V_{DRM}$  rating.)
2. Set *Horizontal* knob to sufficient scale to allow viewing of trace at the required voltage level. (The 100V/DIV scale should be used for testing devices having a  $V_{DRM}$  value of 600 volts or greater; the 50V/DIV scale for testing parts rated from 300 to 500 volts, and so on.)
3. Set *Mode* to *Leakage*.
4. Set *Polarity* to (+).
5. Set *Power Dissipation* to 0.5 watts.
6. Set *Terminal Selector* to *Emitter Grounded-Open Base*.
7. Set *Vertical* knob to approximately ten times the maximum leakage current ( $I_{DRM}$ ,  $I_{RRM}$ ) specified for the device. (For sensitive SCR's, set to 50 microamps.)

Note: The CRT screen readout should show 1.0 percent of the maximum leakage current if the vertical scale is divided by one thousand when leakage current mode is used.

### Procedure 2: $V_{DRM}$ , $I_{DRM}$

To measure the  $V_{DRM}$  and  $I_{DRM}$  parameter:

1. Set *Left-Right Terminal Jack Selector* to correspond with location of test fixture.
2. Set *Variable Collector Supply* to the rated  $V_{DRM}$  of the device and observe the dot on CRT. Read across horizontally from the dot to the vertical current scale. This measured value will be the leakage current. (See Figure 19.3.)

**WARNING: Do NOT exceed  $V_{DRM}/V_{RRM}$  rating of SCR's, triacs, or Quadracs. These devices can be damaged.**

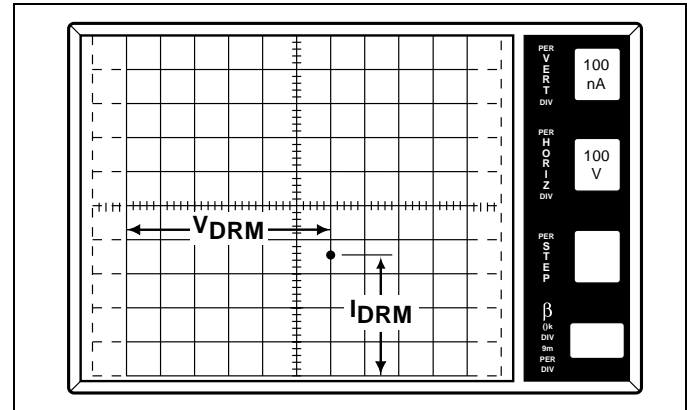

Figure 19.3  $I_{DRM}$  is equal to 350nA at  $V_{DRM}$  equal to 600

### Procedure 3: $V_{RRM}$ , $I_{RRM}$

To measure the  $V_{RRM}$  and  $I_{RRM}$  parameter:

1. Set *Polarity* to (-).
2. Repeat Steps 1 and 2 ( $V_{DRM}$ ,  $I_{DRM}$ ) except substitute  $V_{RRM}$  value for  $V_{DRM}$ . (See Figure 19.4.)

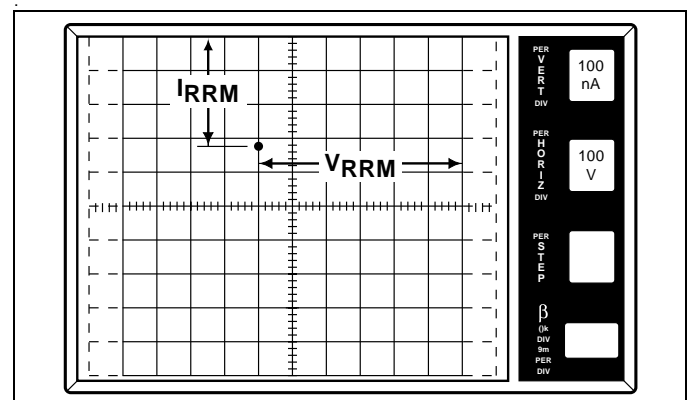

Figure 19.4  $I_{RRM}$  is equal to 340nA at  $V_{RRM}$  equal to 600 volts

### Procedure 4: $V_{TM}$

To measure the  $V_{TM}$  parameter:

1. Set *Terminal Selector* to *Step Generator-Emitter Grounded*.
2. Set *Polarity* to (+).
3. Set *Step/Offset Amplitude* to twice the maximum  $I_{GT}$  rating of the device (to insure the device turns on). For sensitive SCR's, set to 2mA.
4. Set *Max Peak Volts* to 15 volts.
5. Set *Offset* by depressing *Zero*.

6. Set *Rate* by depressing *Norm*.
7. Set *Step Family* by depressing *Rep* (repetitive).
8. Set *Mode* to *DC*.
9. Set *Horizontal* knob to *0.5V/DIV*.
10. Set *Power Dissipation* to *220 Watts* (*100 Watts* on *577*).
11. Set *Number of Steps* to (1).
12. Set *Vertical* knob to a sufficient setting to allow the viewing of 2 times the  $I_{T(RMS)}$  rating of the device ( $I_{T(peak)}$ ) on CRT.

Before continuing with testing, note the following:

- (1) Due to the excessive amount of power that can be generated in this test, only parts with an  $I_{T(RMS)}$  rating of 6.0 amps or less should be tested on standard curve tracer. If devices above 6 amps are to be tested, a TEKTRONIX model 176 high-current module is required.
  - (2) A Kelvin test fixture is required for this test. If a Kelvin fixture is not used, an error in measurement of  $V_{TM}$  will result due to voltage drop in the fixture. If a Kelvin fixture is not available, see the attached instructions for necessary information to wire a test fixture with Kelvin connectors.
13. Set *Left-Right Terminal Jack Selector* to correspond with the location of the test fixture.
  14. Increase *Variable Collector Supply Voltage* until current reaches rated  $I_{T(peak)}$ , which is twice the  $I_{T(RMS)}$  rating of the SCR under test.

**WARNING: Limit test time to 15 seconds maximum after the Variable Collector Supply has been set to  $I_{T(peak)}$ . After the Variable Collector Supply Voltage has been set to  $I_{T(peak)}$ , the test time can automatically be shortened by changing Step Family from repetitive to single by depressing the *Single* button.**

To measure  $V_{TM}$ , follow along horizontal scale to the point where the trace crosses the  $I_{T(peak)}$  value. The distance from the left-hand side of scale to the intersection point is the  $V_{TM}$  value (See Figure 19.5.)

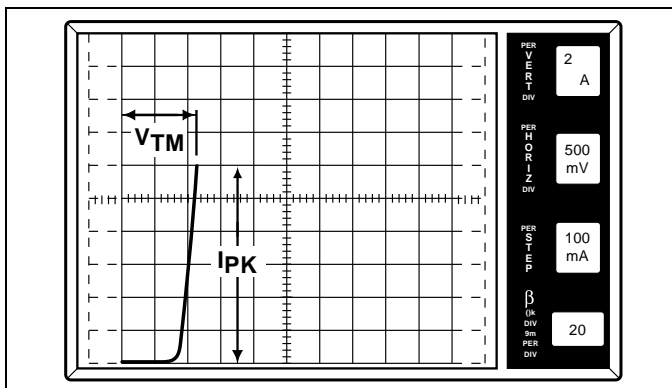

Figure 19.5  $V_{TM}$  is equal to 1.15 volts at  $I_{T(pk)}$  equal to 12 amps

### Procedure 5: $I_H$

To measure the  $I_H$  parameter:

1. Set *Polarity* to (+).
2. Set *Power Dissipation* to *2.2 watts*.
3. Set *Max Peak Volts* to *75 volts*.
4. Set *Mode* to *DC*.

5. Set *Horizontal* knob to *Step Generator*.
6. Set *Vertical* knob to approximately 10\* percent of the maximum  $I_H$  specified.  
\*Due to large variation of holding current values, the scale may have to be adjusted to observe holding current.
7. Set *Number of Steps* to (1).
8. Set *Offset* by depressing *Zero*.
9. Set *Step/Offset Amplitude* to twice the maximum  $I_{GT}$  of the device.
10. Set *Terminal Selector* to *Step Generator-Emitter Grounded*.
11. Set *Step Family* by depressing *Single*.
12. Set *Left-Right Terminal Jack Selector* to correspond with location of test fixture.
13. Increase *Variable Collector Supply* to maximum position (100).
14. Set *Step Family* by depressing *Single*. (This could possibly cause the dot on CRT to disappear, depending on the vertical scale selected.)
15. Change *Terminal Selector* from *Step Generator-Emitter Grounded* to *Open Base-Emitter Grounded*.
16. Decrease *Variable Collector Supply Voltage* to the point where the line on the CRT changes to a dot. The position of the beginning point of the line, just before the line becomes a dot, represents the holding current value (See Figure 19.6.)

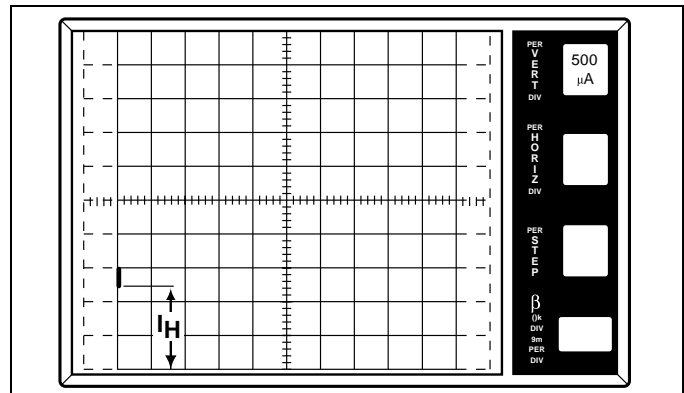

Figure 19.6  $I_H$  is 1.2 mA

### Procedure 6: $I_{GT}$ and $V_{GT}$

To measure the  $I_{GT}$  and  $V_{GT}$  parameter:

1. Set *Polarity* to (+).
2. Set *Number of Steps* to (1).
3. Set *Offset* by depressing *AID*.
4. Set *Offset Multiplier* to 0.0.
5. Set *Terminal Selector* to *Step Generator-Emitter Grounded*.
6. Set *Mode* to *Norm*.
7. Set *Max Peak Volts* to *15 volts*.
8. Set *Power Dissipation* to *2.2 watt.s* (For sensitive SCRs, set at 0.5 watts.)
9. Set *Horizontal* knob to *2V/DIV*.
10. Set *Vertical* knob to *50mA/DIV*.

# Testing Teccor Semiconductor Devices Using Curve Tracers

- Increase *Variable Collector Supply* until voltage reaches 12 volts on CRT.
- After 12 volt setting is completed, change *Horizontal* knob to *Step Generator*.

## Procedure 7: $I_{GT}$

To measure the  $I_{GT}$  parameter:

- Set *Step/Offset Amplitude* to 20 percent of maximum rated  $I_{GT}$ .  
Note:  $R_{GK}$  should be removed when testing  $I_{GT}$ .
- Set *Left-Right Terminal Jack Selector* to correspond with location of the test fixture.
- Gradually increase *Offset Multiplier* until device reaches the conduction point. (See Figure 19.7.) Measure  $I_{GT}$  by following horizontal axis to the point where the vertical line crosses axis. This measured value is  $I_{GT}$ .

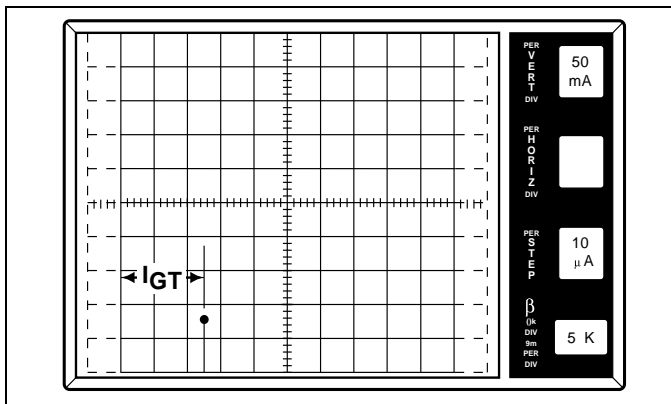

Figure 19.7  $I_{GT}$  is  $25\mu A$

## Procedure 8: $V_{GT}$

To measure the  $V_{GT}$  parameter:

- Set *Offset Multiplier* to 0.0.
- Set *Step Offset Amplitude* to 20 percent rated  $V_{GT}$ .
- Set *Left-Right Terminal Jack Selector* to correspond with location of test fixture.
- Gradually increase *Offset Multiplier* until device reaches the conduction point (See Figure 19.8.) Measure  $V_{GT}$  by following horizontal axis to the point where the vertical line crosses axis. This measured value is  $V_{GT}$ .

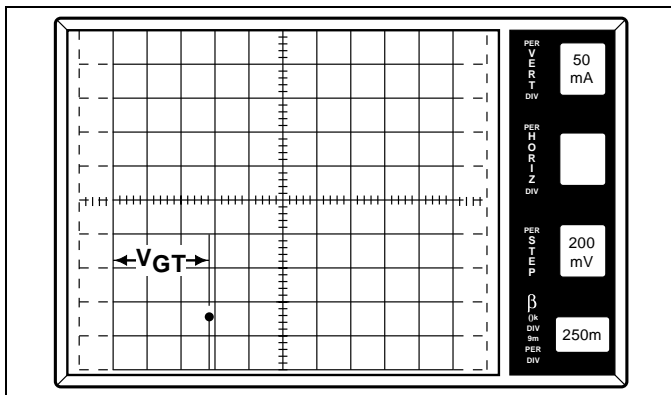

Figure 19.8  $V_{GT}$  is 580mV

## TRIACS

Triacs are full-wave bidirectional AC switches which are turned on when current is supplied to the gate terminal of the device. If gate control in all four (4) quadrants is required, then a sensitive gate triac is needed, whereas a standard triac can be used if gate control is only required in Quadrants I-III.

To connect the triac:

- Connect the *Gate* to the *Base Terminal* (B).
- Connect *MT1* to the *Emitter Terminal* (E).
- Connect *MT2* to the *Collector Terminal* (C).

To begin testing, perform the following procedures.

## Procedure 1: $(+)V_{DRM}$ , $(+)I_{DRM}$ , $(-)V_{DRM}$ , $(-)I_{DRM}$

Note: The (+) and (-) symbols are used to designate the polarity MT2 with reference to MT1.

To measure the  $(+)V_{DRM}$ ,  $(+)I_{DRM}$ ,  $(-)V_{DRM}$ , and  $(-)I_{DRM}$  parameter:

- Set *Collector Voltage Supply Range* to appropriate *Max Peak Volts* for device under test. (Value selected should be equal to the device's  $V_{DRM}$  rating.)

**WARNING: Do NOT exceed  $V_{DRM}/V_{RRM}$  rating of SCRs, triacs, or Quadacs. These devices can be damaged.**

- Set *Horizontal* knob to sufficient scale to allow viewing of trace at the required voltage level. (The 100V/DIV scale should be used for testing devices having a  $V_{DRM}$  rating of 600 volts or greater; the 50V/DIV scale for testing parts rated from 30 to 500 volts, and so on.)
- Set *Mode* to *Leakage*.
- Set *Polarity* to (+).
- Set *Power Dissipation* to 0.5 watts.
- Set *Terminal Selector* to *Emitter Grounded-Open Base*.
- Set *Vertical* knob to ten times the maximum leakage current ( $I_{DRM}$ ) specified for the device.

Note: The CRT screen readout should show 1.0 percent of the maximum leakage current. The vertical scale is divided by one thousand when leakage mode is used.

## Procedure 2: $(+)V_{DRM}$ , $(+)I_{DRM}$

To measure the  $(+)V_{DRM}$  and  $(+)I_{DRM}$  parameter:

- Set *Left-Right Terminal Jack Selector* to correspond with location of the test fixture.
- Increase *Variable Collector Supply Voltage* to the rated  $V_{DRM}$  of the device and observe the dot on the CRT. Read across horizontally from the dot to the vertical current scale. This measured value will be the leakage current. (See Figure 19.9.)

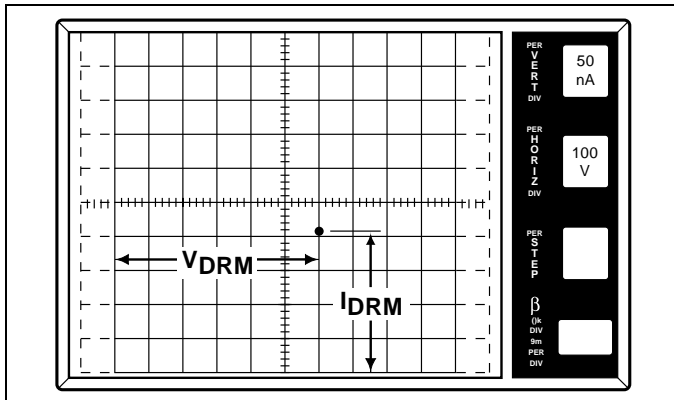

Figure 19.9 (+)I<sub>DRM</sub> is equal to 205nA at (+)V<sub>DRM</sub> equal to 600 volts

### Procedure 3: (-)V<sub>DRM</sub>, (-)I<sub>DRM</sub>

To measure the (-)V<sub>DRM</sub> and (-)I<sub>DRM</sub> parameter:

1. Set *Polarity* to (-).
2. Repeat Procedures 1 and 2. (Read measurements from upper right corner of the screen.)

### Procedure 4: V<sub>TM</sub> (Forward and Reverse)

To measure the V<sub>TM</sub> (Forward and Reverse) parameter:

1. Set *Terminal Selector* to *Step Generator-Emitter Grounded*.
2. Set *Step/Offset Amplitude* to twice the maximum I<sub>GT</sub> rating of the device (to insure the device turns on).
3. Set *Collector Voltage Supply Range* to *15 Max Peak volts*.
4. Set *Offset* by depressing "Zero".
5. Set *Rate* by depressing "Norm".
6. Set *Step Family* by depressing *Rep* (Repetitive).
7. Set *Mode* to *Norm*.
8. Set *Horizontal knob* to *0.5V/DIV*.
9. Set *Power Dissipation* to *220 watts (100 watts on 577)*.
10. Set *Number of Steps* to (1).
11. Set *Set/Offset Polarity* to non-inverted (button extended; on 577 button depressed).
12. Set *Vertical knob* to a sufficient setting to allow the viewing of 1.4 times the I<sub>T(RMS)</sub> rating of the device [I<sub>T(peak)</sub> on CRT].

Note the following:

- Due to the excessive amount of power that can be generated in this test, only parts with an IT (RMS) rating of 8.0 amps or less should be tested on standard curve tracer. If devices above 8 amps are to be tested, a TEKTRONIX model 176 high-current module is required.
- A Kelvin test fixture is required for this test. If a Kelvin fixture is not used, an error in measurement of V<sub>TM</sub> will result due to voltage drop in fixture. If a Kelvin fixture is not available, see the attached instructions for necessary information to wire a test fixture with Kelvin connections.

### Procedure 5: V<sub>TM</sub> (Forward)

To measure the V<sub>TM</sub> (Forward) parameter:

1. Set *Polarity* to (+).
2. Set *Left-Right Terminal Jack Selector* to correspond with location of test fixture.
3. Increase *Variable Collector Supply Voltage* until current reaches rated I<sub>T(peak)</sub>, which is 1.4 times I<sub>T(RMS)</sub> rating of the triac under test.

**WARNING: Limit test time to 15 seconds maximum. After the Variable Collector Supply Voltage has been set to I<sub>T(peak)</sub>, the test time can automatically be set to a short test time by changing Step Family from repetitive to single by depressing the Single button.**

To measure V<sub>TM</sub>, follow along horizontal scale to the point where the trace crosses the I<sub>T(peak)</sub> value. The distance from the left-hand side of scale to the crossing point is the V<sub>TM</sub> value. (See Figure 19.10.)

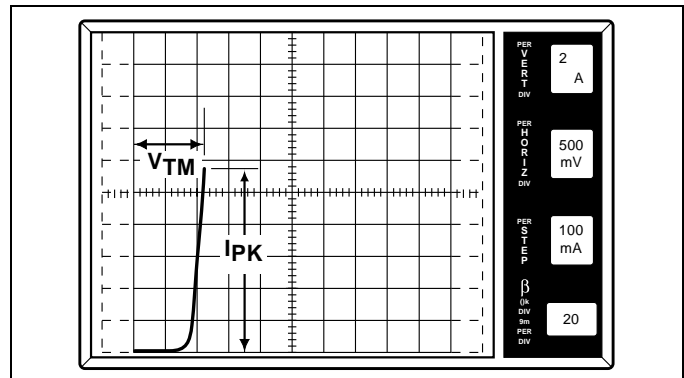

Figure 19.10 V<sub>TM</sub> (forward) is equal to 1.1 volts at I<sub>PK</sub> equal to 11.3 amps (8 amps [RMS])

### Procedure 6: V<sub>TM</sub> (Reverse)

To measure the V<sub>TM</sub> (Reverse) parameter:

1. Set *Polarity* to (-).
2. Set *Left-Right Terminal Jack Selector* to correspond with the location of the test fixture.
3. Increase *Variable Collector Supply Voltage* until current reaches rated I<sub>T(peak)</sub>.
4. Measure V<sub>TM(Reverse)</sub> per above.

### Procedure 7: I<sub>H</sub> (Forward & Reverse)

To measure the I<sub>H</sub> (Forward and Reverse) parameter:

1. Set *Step/Offset Amplitude* to twice the I<sub>GT</sub> rating of the device.
2. Set *Power Dissipation* to *10.0 watts*.
3. Set *Max Peak Volts* to *75 volts*.
4. Set *Mode* to *DC*.
5. Set *Horizontal knob* to *Step Generator*.
6. Set *Vertical knob* to approximately 10\* percent of the maximum I<sub>H</sub> specified.

\*Due to large variation of holding current values, the scale may have to be adjusted to observe holding current.

# Testing Teccor Semiconductor Devices Using Curve Tracers

- Set *Number of Steps* to (1).
- Set *Step Offset Polarity* to non-inverted (button extended, on 577 button depressed).
- Set *Offset* by depressing *Zero*.
- Set *Terminal Selector* to *Step Generator-Emitter Grounded*.

## Procedure 8: $I_H$ (Forward)

To measure the  $I_H$  (Forward) parameter:

- Set *Polarity* to (+)
- Set *Left-Right Terminal Jack Selector* to correspond with location of test fixture.
- Increase *Variable Collector Supply Voltage* to maximum position (100).
- Set *Step Family* by depressing *Single*.  
This could possibly cause the dot on the CRT to disappear, depending on the vertical scale selected).
- Decrease *Variable Collector Supply Voltage* to the point where the line on the CRT changes to a dot. The position of the beginning point of the line, just before the line becomes a dot, represents the holding current value (See Figure 19.11.)

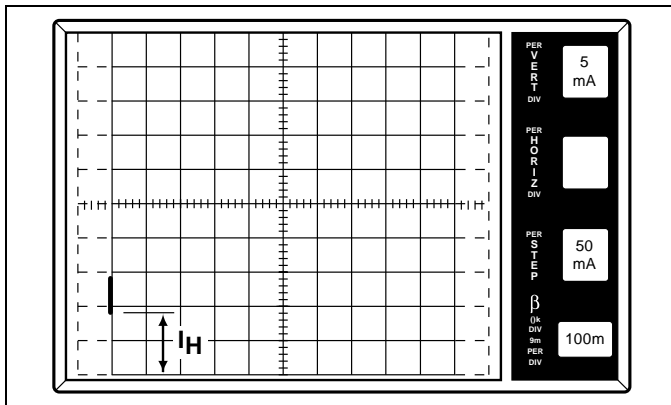

Figure 19.11  $I_H$  (Forward) is 8.2mA

## Procedure 9: $I_H$ (Reverse)

To measure the  $I_H$  (Reverse) parameter:

- Set *Polarity* to (-).
- Repeat Procedure 7 measuring  $I_H$ (Reverse). (Read measurements from upper-right corner of the screen.)

## Procedure 10: $I_{GT}$

To measure the  $I_{GT}$  parameter:

- Set *Polarity* to (+).
- Set *Number of Steps* to (1).
- Set *Offset* by depressing *Aid*.  
(On 577, also set *Zero* button to *Offset*. Button is extended.)
- Set *Offset Multiplier* to 0.0.
- Set *Terminal Selector* to *Step Generator-Emitter Grounded*.
- Set *Mode* to *Norm*.
- Set *Max Peak Volts* to 15 volts.
- Set *Power Dissipation* to 10.0 watts.
- Set *Step Family* by depressing *Single*.

- Set *Horizontal* knob to 2V/DIV.
- Set *Vertical* knob to 50mA/DIV.
- Set *Step/Offset Polarity* to non-inverted position (button extended, on 577 button depressed).
- Set *Variable Collector Supply Voltage* until voltage reaches 12 volts on CRT.
- After 12 volt setting is completed, change *Horizontal* knob to *Step Generator*.

## Procedure 11: $I_{GT}$ – Quadrant I [MT2 (+) Gate (+)]

To measure the  $I_{GT}$  – Quadrant I parameter:

- Set *Step/Offset Amplitude* to approximately 10 percent of rated  $I_{GT}$ .
- Set *Left-Right Terminal Jack Selector* to correspond with location of test fixture.
- Gradually increase *Offset Multiplier* until device reaches conduction point. (See Figure 19.12.) Measure  $I_{GT}$  by following horizontal axis to the point where the vertical line passes through the axis. This measured value will be  $I_{GT}$ .

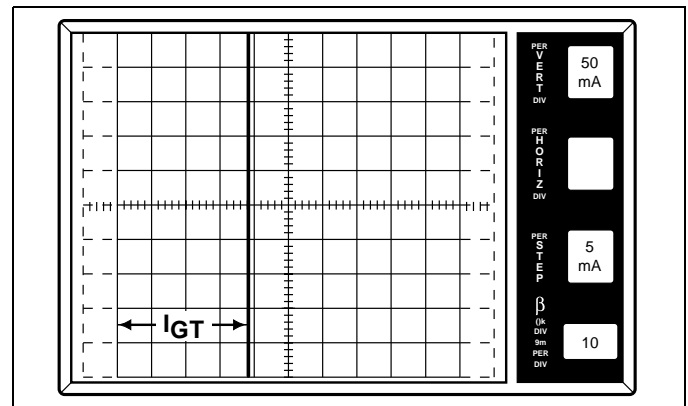

Figure 19.12  $I_{GT}$  in QI is 18.8mA

## Procedure 12: $I_{GT}$ – Quadrant II [MT2 (+) Gate (-)]

To measure the  $I_{GT}$  – Quadrant II parameter:

- Set *Step/Offset Polarity* by depressing *Invert* (release button on 577).
- Set *Polarity* to (+).
- Set observed dot to bottom right corner of CRT grid by turning the horizontal position knob. When testing in Quadrant II is completed, return dot to original position.
- Repeat Procedure 11.

## Procedure 13: $I_{GT}$ – Quadrant III [MT2 (-) Gate (-)]

To measure the  $I_{GT}$  – Quadrant III parameter:

- Set *Polarity* to (-).
- Set *Step/Offset Polarity* to non-inverted position (button extended, on 577 button depressed).
- Repeat Procedure 11. (See Figure 19.13.)

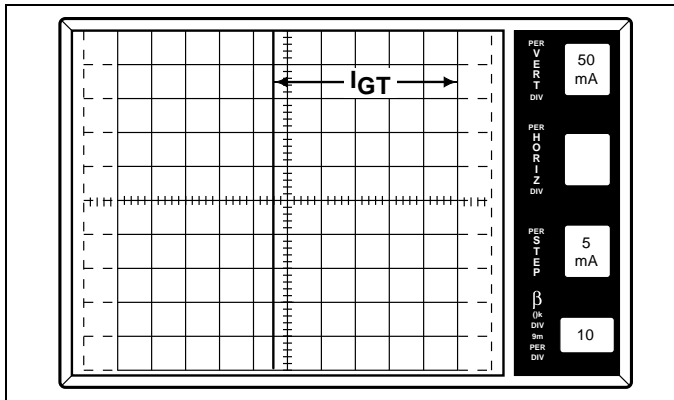

Figure 19.13  $I_{GT}$  in QIII is 27mA

### Procedure 14: $I_{GT}$ – Quadrant IV [MT2 (-) Gate (+)]

To measure the  $I_{GT}$  – Quadrant IV parameter:

1. Set *Polarity* to (-).
2. Set *Step/Offset Polarity* by depressing *Invert* (release button on 577).
3. Set observed dot to top left corner of CRT grid by turning the horizontal position knob. When testing in Quadrant IV is completed, return dot to original position.
4. Repeat Procedure 11.

### Procedure 15: $V_{GT}$

To measure the  $V_{GT}$  parameter:

1. Set *Polarity* to (+).
2. Set *Number of Steps* to (1).
3. Set *Offset* by depressing *AID*. (On 577, also set *Zero* button to *Offset*. Button is extended.)
4. Set *Offset Multiplier* to 0.0.
5. Set *Terminal Selector* to *Step Generator-Emitter Grounded*.
6. Set *Mode* to *Norm*.
7. Set *Max Peak Volts* to 15 volts.
8. Set *Power Dissipation* to 10 watts.
9. Set *Step Family* by depressing *Single*.
10. Set *Horizontal knob* to 2 volts/DIV.
11. Set *Step/Offset Polarity* to non-inverted position (button extended, on 577 button depressed).
12. Set *Current Limit* to 500mA (not available on 577).
13. Increase *Variable Collector Supply Voltage* until voltage reaches 12 volts on CRT.
14. After 12 volt setting is completed, change *Horizontal knob* to *Step Generator*.

### Procedure 16: $V_{GT}$ – Quadrant I [MT2 (+) Gate (+)]

To measure the  $V_{GT}$  – Quadrant I parameter:

1. Set *Step/Offset Amplitude* to 20 percent of rated  $V_{GT}$ .
2. Set *Left-Right Terminal Jack Selector* to correspond with location of test fixture.

3. Gradually increase *Offset Multiplier* until device reaches conduction point (See Figure 19.14.) Measure  $V_{GT}$  by following horizontal axis to the point where the vertical line passes through the axis. This measured value will be  $V_{GT}$ .

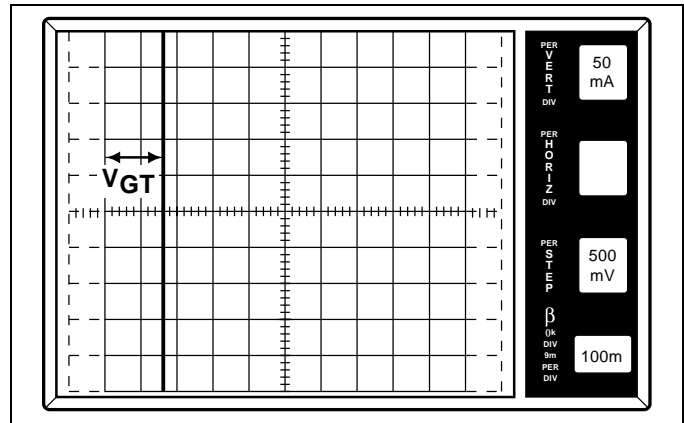

Figure 19.14  $V_{GT}$  in QI is 780mV

### Procedure 17: $V_{GT}$ – Quadrant II [MT2 (+) Gate (-)]

To measure the  $V_{GT}$  – Quadrant II parameter:

1. Set *Step/Offset Polarity* by depressing *Invert* (release button on 577).
2. Set *Polarity* to (+).
3. Set observed dot to bottom right corner of CRT grid by turning the horizontal position knob. When testing in Quadrant II is completed, return dot to original position.
4. Repeat Procedure 16.

### Procedure 18: $V_{GT}$ – Quadrant III [MT2 (-) Gate (-)]

To measure the  $V_{GT}$  – Quadrant III parameter:

1. Set *Polarity* to (-).
2. Set *Step/Offset Polarity* to non-inverted position (button extended, on 577 button depressed).
3. Repeat Procedure 16. (See Figure 19.15.)

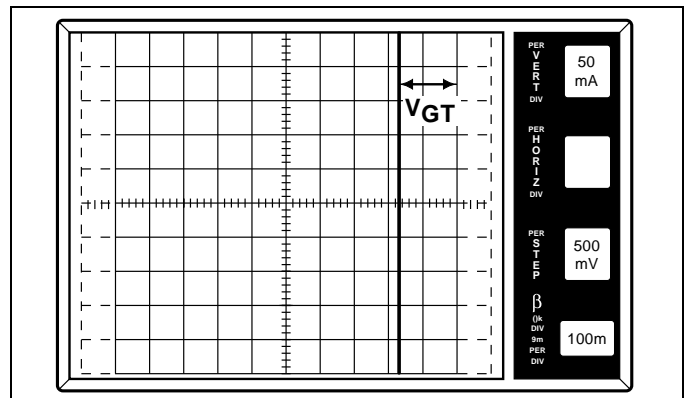

Figure 19.15  $V_{GT}$  in QIII is 820mV

# Testing Teccor Semiconductor Devices Using Curve Tracers

## Procedure 19: $V_{GT}$ – Quadrant IV [MT2 (-) Gate (+)]

To measure the  $V_{GT}$  – Quadrant IV parameter:

1. Set *Polarity* to (-).
2. Set *Step/Offset Polarity* by depressing *Invert* (release button on 577).
3. Set observed dot to top left corner of CRT grid by turning the horizontal position knob. When testing is complete in Quadrant IV, return dot to original position.
4. Repeat Procedure 16.

## QUADRACS

QUADRACS are simply triacs with an internally-mounted diac. As with triacs, QUADRACS are bidirectional AC switches which are gate controlled for either polarity of main terminal voltage.

To connect the QUADRAC:

1. Connect *Trigger* to *Base Terminal (B)*
2. Connect *MT1* to *Emitter Terminal (E)*
3. Connect *MT2* to *Collector Terminal (C)*

To begin testing, perform the following procedures.

### Procedure 1: (+) $V_{DRM}$ , (+) $I_{DRM}$ , (-) $V_{DRM}$ , (-) $I_{DRM}$

Note: the (+) and (-) symbols are used to designate the polarity of MT2 with reference to MT1.

To measure the (+) $V_{DRM}$ , (+) $I_{DRM}$ , (-) $V_{DRM}$ , and (-) $I_{DRM}$  parameter:

1. Set *Collector Voltage Supply Range* to appropriate *Max Peak Volts* for device under test. (Value selected should be equal to or greater than the device's  $V_{DRM}$  rating).
2. Set *Horizontal* knob to sufficient scale to allow viewing of trace at the required voltage level. (The 100V/DIV scale should be used for testing devices having a  $V_{DRM}$  rating of 600 volts or greater; the 50V/DIV scale for testing parts rated from 300 to 500 volts, and so forth).
3. Set *Mode* to *Leakage*.
4. Set *Polarity* to (+).
5. Set *Power Dissipation* to 0.5 watts.
6. Set *Terminal Selector* to *Emitter Grounded-Open Base*.
7. Set *Vertical* knob to ten times the maximum leakage current ( $I_{DRM}$ ) specified for the device.

Note: The CRT readout should show 1.0 percent of the maximum leakage current. The vertical scale is divided by one thousand when the leakage mode is used.

### Procedure 2: (+) $V_{DRM}$ and (+) $I_{DRM}$

To measure the (+) $V_{DRM}$  and (+) $I_{DRM}$  parameter:

1. Set *Left-Right Terminal Jack Selector* to correspond with the location of the test fixture.
2. Increase *Variable Collector Supply Voltage* to the rated  $V_{DRM}$  of the device and observe the dot on the CRT. (Read across horizontally from the dot to the vertical current scale.) This measured value will be the leakage current. (See Figure 19.16.)

**WARNING:** Do NOT exceed  $V_{DRM}/V_{RRM}$  rating of SCRs, triacs, or Quadracs. These devices can be damaged.

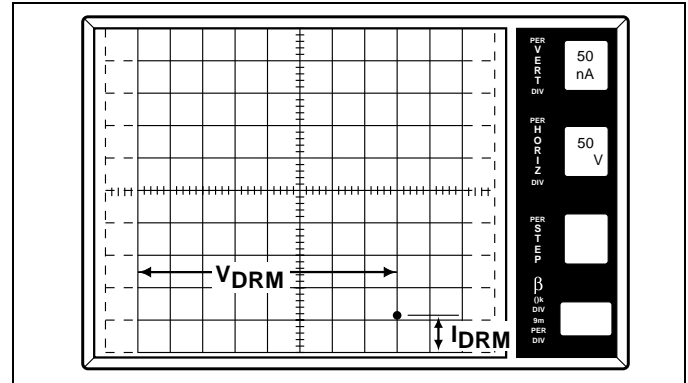

Figure 19.16 (+) $I_{DRM}$  is equal to 51nA at (+) $V_{DRM}$  equal to 400 volts

### Procedure 3: (-) $V_{DRM}$ and (-) $I_{DRM}$

To measure the (-) $V_{DRM}$  and (-) $I_{DRM}$  parameter:

1. Set *Polarity* to (-).
2. Repeat Procedures 1 and 2. (Read measurements from upper right corner of screen).

### Procedure 4: $V_{BO}$ , $I_{BO}$ , $\Delta V_{BO}$ (QUADRAC Trigger Diac or Discrete Diac)

To connect the QUADRAC:

1. Connect *MT1* to *Emitter Terminal (E)*.
2. Connect *MT2* to *Collector Terminal (C)*.
3. Connect *Trigger Terminal* to *MT2 Terminal* through a 10 Ohm resistor.

To measure the  $V_{BO}$ ,  $I_{BO}$ , and  $\Delta V_{BO}$  parameter:

1. Set *Collector Voltage Supply Range* to 75 Max Peak volts.
2. Set *Horizontal* knob to 10 volts/DIV.
3. Set *Vertical* knob to 50 microamps/DIV.
4. Set *Polarity* to AC.
5. Set *Mode* to Norm.
6. Set *Power Dissipation* to 0.1 watts.
7. Set *Terminal Selector* to *Emitter Grounded-Open Base*.

### Procedure 5: $V_{BO}$ (Positive and Negative)

To measure the  $V_{BO}$  (Positive and Negative) parameter:

1. Set *Left-Right Terminal Jack Selector* to correspond with the location of the test fixture.
2. Increase *Variable Collector Supply Voltage* until breakover occurs. (See Figure 19.18.) The voltage at which current begins to flow and the voltage does not increase is the  $V_{BO}$  value.

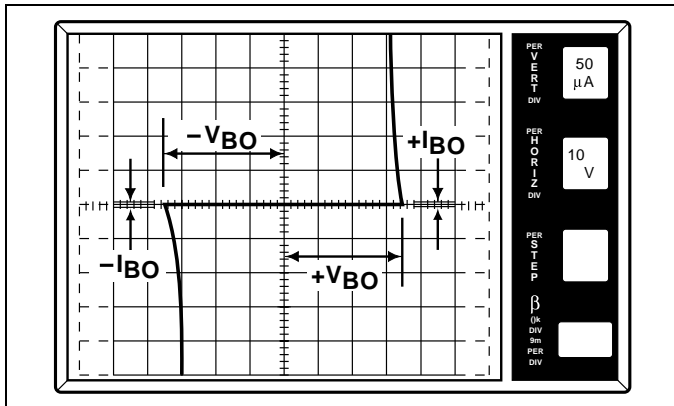

Figure 19.17 (+) $V_{BO}$  is equal to 35 volts; (-) $V_{BO}$  is equal to 36 volts; ( $\pm$ ) $I_{BO}$  is less than 10A

### Procedure 6: $I_{BO}$ (Positive and Negative)

To measure the  $I_{BO}$  (Positive and Negative) parameter, at the  $V_{BO}$  point, measure the amount of device current just before the device reaches the breakover point. The measured current at this point is the  $I_{BO}$  value.

Note: If  $I_{BO}$  is less than 10 microamps, the current cannot readily be seen on curve tracer.

### Procedure 7: $\Delta V_{BO}$ (Voltage Breakover Symmetry)

To measure the  $\Delta V_{BO}$  (Voltage Breakover Symmetry) parameter:

1. Measure positive and negative  $V_{BO}$  values per Procedure 5.
2. Subtract the absolute value of  $V_{BO}$  (-) from  $V_{BO}$  (+).

The absolute value of the result is:

$$\Delta V_{BO}: \Delta V_{BO} = [ | +V_{BO} | - | -V_{BO} | ]$$

### Procedure 8: $V_{TM}$ (Forward and Reverse)

To test  $V_{TM}$ , the quadrac must be connected the same as when testing  $V_{BO}$ ,  $I_{BO}$ , and  $\Delta V_{BO}$ .

To connect the QUADRAC:

1. Connect *MT1* to *Emitter Terminal (E)*.
2. Connect *MT2* to *Collector Terminal (C)*.
3. Connect *Trigger Terminal* to *MT2 Terminal* through a 10 Ohm resistor.

Note the following:

- Due to the excessive amount of power that can be generated in this test, only parts with an  $I_{T(RMS)}$  rating of 8.0 amps or less should be tested on standard curve tracer. If devices above 8 amps are to be tested, a "TEKTRONIX" model 176 high-current module is required.
- A Kelvin test fixture is required for this test. If a Kelvin fixture is not used, an error in measurement of  $V_{TM}$  will result due to voltage drop in fixture. If a Kelvin fixture is not available, see the attached instructions for necessary information to wire a test fixture with Kelvin connections.

To measure the  $V_{TM}$  (Forward and Reverse) parameter:

1. Set *Terminal Selector* to *Emitter Grounded-Open Base*.
2. Set *Max Peak Volts* to 75 volts.
3. Set *Mode* to *Norm*.

4. Set *Horizontal knob* to 0.5 V/DIV.
5. Set *Power Dissipation* to 220 watts (100 watts on a 577).
6. Set *Vertical knob* to a sufficient setting to allow the viewing of 1.4 times the  $I_{T(RMS)}$  rating of the device  $I_{T(peak)}$  on the CRT.

### Procedure 9: $V_{TM}$ (Forward)

To measure the  $V_{TM}$  (Forward) parameter:

1. Set *Polarity* to (+).
2. Set *Left-Right Terminal Jack Selector* to correspond with the location of the test fixture.
3. Increase *Variable Collector Supply Voltage* until current reaches rated  $I_{T(peak)}$ , which is 1.4 times the  $I_{T(RMS)}$  rating of the triac under test.

**WARNING: Limit test time to 15 seconds maximum.**

4. To measure  $V_{TM}$ , follow along horizontal scale to the point where the trace crosses the  $I_{T(peak)}$  value. This horizontal distance is the  $V_{TM}$  value. (See Figure 19.18.)

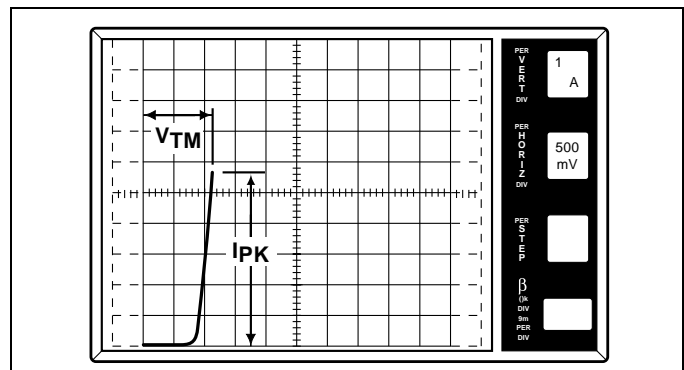

Figure 19.18  $V_{TM}$  (Forward) is equal to 1.1 volts at  $I_{pk}$  equal to 5.6 amps

### Procedure 10: $V_{TM}$ (Reverse)

To measure the  $V_{TM}$  (Reverse) parameter:

1. Set *Polarity* to (-).
2. Set *Left-Right Terminal Jack Selector* to correspond with the location of the test fixture.
3. Increase *Variable Collector Supply Voltage* until current reaches rated  $I_{T(peak)}$ .
4. Measure  $V_{TM(Reverse)}$  the same as in Procedure 8. (Read measurements from upper right corner of screen).

### Procedure 11: $I_H$ (Forward and Reverse)

For these steps, it is again necessary to connect the *Trigger* to *MT2* through a 10 Ohm resistor. The other connections remain the same.

To measure the  $I_H$  (Forward and Reverse) parameter:

1. Set *Power Dissipation* to 50 watts.
2. Set *Max Peak Volts* to 75 volts.
3. Set *Mode* to *DC*.
4. Set *Horizontal knob* to 5V/DIV.

# Testing Teccor Semiconductor Devices Using Curve Tracers

- Set *Vertical* knob to approximately 10\* percent of the maximum  $I_H$  specified.  
\*Due to large variations of holding current values, the scale may have to be adjusted to observe holding current.
- Set *Terminal Selector* to *Emitter Grounded-Open Base*.

## Procedure 12: $I_{H(Forward)}$

To measure the  $I_{H(Forward)}$  parameter:

- Set *Polarity* to (+).
- Set *Left-Right Terminal Jack Selector* to correspond with the location of the test fixture.
- Increase *Variable Collector Supply Voltage* to maximum position (100).

Note: Depending on the vertical scale being used, the dot may disappear completely from the screen.

- Decrease *Variable Collector Supply Voltage* to the point where the line on the CRT changes to a dot. The position of the beginning point of the line, just before the line changes to a dot, represents the  $I_H$  value (See Figure 19.19.)

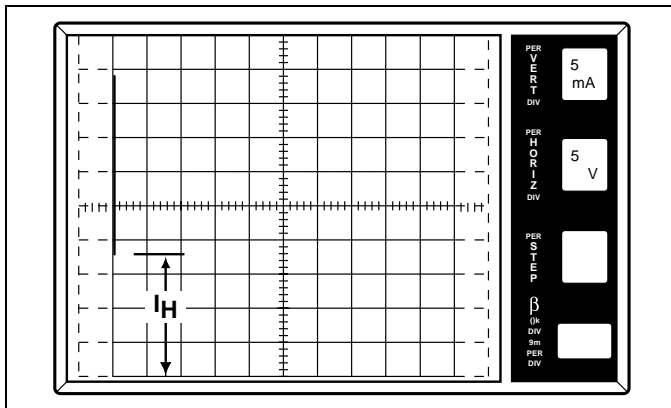

Figure 19.19  $I_{H(Forward)}$  is equal to 18mA

## Procedure 13: $I_{H(Reverse)}$

To measure the  $I_{H(Reverse)}$  parameter:

- Set *Polarity* to (-).
- Continue testing per Procedure 12 for measuring  $I_{H(Reverse)}$ .

## SIDACS

The Sidac is a bidirectional voltage-triggered switch. Upon application of a voltage exceeding the sidac breakover voltage point, the sidac switches on through a negative resistance region (similar to a diac) to a low on-state voltage. Conduction continues until current is interrupted or drops below minimum required holding current.

To connect the Sidac:

- Connect *MT1* to the *Emitter Terminal (E)*.
- Connect *MT2* to the *Collector Terminal (C)*.

To begin testing, perform the following procedures.

## Procedure 1: (+) $V_{DRM}$ , (+) $I_{DRM}$ , (-) $V_{DRM}$ , (-) $I_{DRM}$

Note: the (+) and (-) symbols are used to designate the polarity of MT2 with reference to MT1.

To measure the (+)  $V_{DRM}$ , (+)  $I_{DRM}$ , (-)  $V_{DRM}$ , and (-)  $I_{DRM}$  parameter:

- Set *Collector Voltage Supply Range* to *1500 Max Peak volts*.
- Set *Horizontal* knob to *50 volts/DIV*.
- Set *Mode* to *Leakage*.
- Set *Polarity* to (+).
- Set *Power Dissipation* to *2.2 watts*.
- Set *Terminal Selector* to *Emitter Grounded-Open Base*.
- Set *Vertical* knob to *50 microamps/DIV*. (Due to leakage mode, the CRT readout will show 50 nA.)

## Procedure 2: (+) $V_{DRM}$ and (+) $I_{DRM}$

To measure the (+)  $V_{DRM}$  and (+)  $I_{DRM}$  parameter:

- Set *Left-Right Terminal Jack Selector* to correspond with the location of the test fixture.
- Increase *Variable Collector Supply Voltage* to the rated  $V_{DRM}$  of the device and observe the dot on the CRT. Read across horizontally from the dot to the vertical current scale. This measured value will be the leakage current. (See Figure 19.20.)

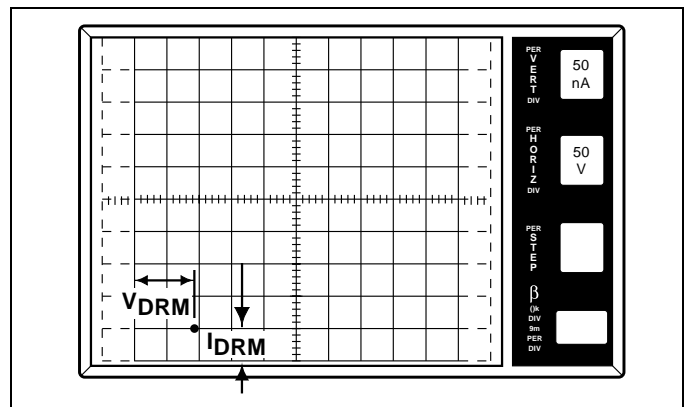

Figure 19.20  $I_{DRM}$  is equal to 50nA at  $V_{DRM}$  equal to 90 volts

## Procedure 3: (-) $V_{DRM}$ and (-) $I_{DRM}$

To measure the (-)  $V_{DRM}$  and (-)  $I_{DRM}$  parameter:

- Set *Polarity* to (-).
- Repeat Procedures 1 and 2. (Read measurements from upper right corner of the screen).

## Procedure 4: $V_{BO}$ and $I_{BO}$

To measure the  $V_{BO}$  and  $I_{BO}$  parameter:

- Set *Collector Voltage Supply Range* to *1500 Max Peak volts*.
- Set *Horizontal* knob to a sufficient scale to allow viewing of trace at the required voltage level (50 volts/DIV for 95-215 volt  $V_{BO}$  range devices and 100 volts/DIV for devices having  $V_{BO} \geq 15$  volts).
- Set *Vertical* knob to *50 microamps/DIV*.
- Set *Polarity* to *AC*.
- Set *Mode* to *Norm*.
- Set *Power Dissipation* to *10 watts*.

7. Set *Terminal Selector* to *Emitter Grounded-Open Base*.
8. Set *Left-Right Terminal Jack Selector* to correspond with location of test fixture.

## Procedure 5: $V_{BO}$

To measure the  $V_{BO}$  parameter, increase *Variable Collector Supply Voltage* until breakover occurs. (See Figure 19.21.) The voltage at which current begins to flow and voltage on CRT does not increase is the  $V_{BO}$  value.

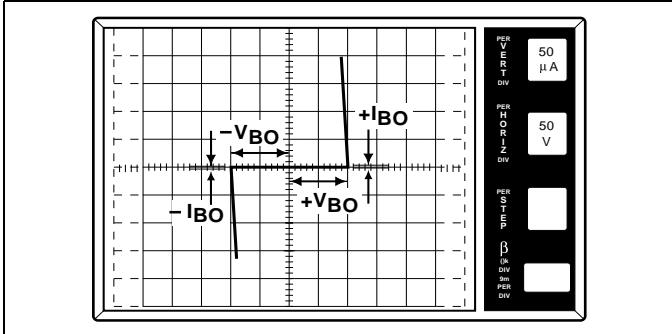

Figure 19.21 (+) $V_{BO}$  is equal to 100 volts; (-) $V_{BO}$  is equal to 100 volts; ( $\pm$ ) $I_{B0}$  is less than 10 $\mu$ A

## Procedure 6: $I_{B0}$

To measure the  $I_{B0}$  parameter, at the  $V_{BO}$  point, measure the amount of device current just before the device reaches the breakover mode. The measured current at this point is the  $I_{B0}$  value.

Note: If  $I_{B0}$  is less than 10 microamps, the current cannot readily be seen on the curve tracer.

## Procedure 7: $I_H$ (Forward and Reverse)

To measure the  $I_H$  (Forward and Reverse) parameter:

1. Set *Collector Voltage Supply Range* to *1500 Max Peak volts* (*400 Max Peak volts* on 577).
2. Set *Horizontal knob* to a sufficient scale to allow viewing of trace at the required voltage level (50 volts/DIV for devices with  $V_{BO}$  range from 95-215 volts, and 100 volts/DIV for devices having  $V_{BO} \geq 215$  volts).
3. Set *Vertical knob* to 20 percent of maximum holding current specified.
4. Set *Polarity* to *AC*.
5. Set *Mode* to *Norm*.
6. Set *Power Dissipation* to *220 watts* (*100 watts* on 577).
7. Set *Terminal Selector* to *Emitter Grounded-Open Base*.
8. Set *Left-Right Terminal Jack Selector* to correspond with the location of the test fixture.

**WARNING: Limit test time to 15 seconds maximum.**

9. Increase *Variable Collector Supply Voltage* until device breakover and turns on. (See Figure 19.22.)

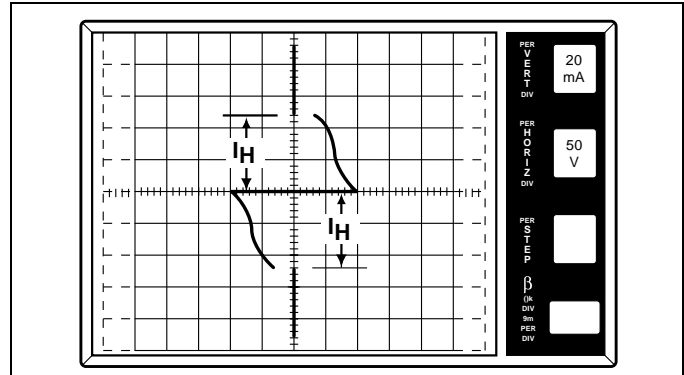

Figure 19.22  $I_H$  is equal to 48mA in both forward and reverse directions  
 $I_H$  is the vertical distance between the center horizontal axis and the beginning of the line located on center vertical axis.

## Procedure 8: $V_{TM}$ (Forward and Reverse)

To measure the  $V_{TM}$  (Forward and Reverse) parameter:

1. Set *Collector Voltage Supply Range* to *350 Max Peak volts*.
2. Set *Horizontal knob* to *0.5 volts/DIV*.
3. Set *Vertical knob* to *.5 amps/DIV*.
4. Set *Polarity* to (+).
5. Set *Mode* to *Norm*.
6. Set *Power Dissipation* to *220 watts* (*100 watts* on 577).
7. Set *Terminal Selector* to *Emitter Grounded-Open Base*.

Before continuing with testing, note the following:

A Kelvin test fixture is required for this test. If a Kelvin fixture is not used, an error in measurement of  $V_{TM}$  will result due to voltage drop in fixture. If a Kelvin fixture is not available, see the attached instructions for necessary information to wire a test fixture with Kelvin Connections.

To continue testing, perform the following procedures.

## Procedure 9: $V_{TM}$ (Forward)

To measure the  $V_{TM}$  (Forward) parameter:

1. Set "*Left-Right Terminal Jack Selector*" to correspond with the location of the test fixture.
2. Increase "*Variable Collector Supply Voltage*" until current reaches rated  $I_{T(peak)}$ , which is 1.4 times the  $I_{T(RMS)}$  rating of the sidac.

**WARNING: Limit test time to 15 seconds.**

3. To measure  $V_{TM}$ , follow along horizontal scale to the point where the trace crosses the  $I_{T(peak)}$  value. This horizontal distance is the  $V_{TM}$  value. (See Figure 19.23.)

# Testing Teccor Semiconductor Devices Using Curve Tracers

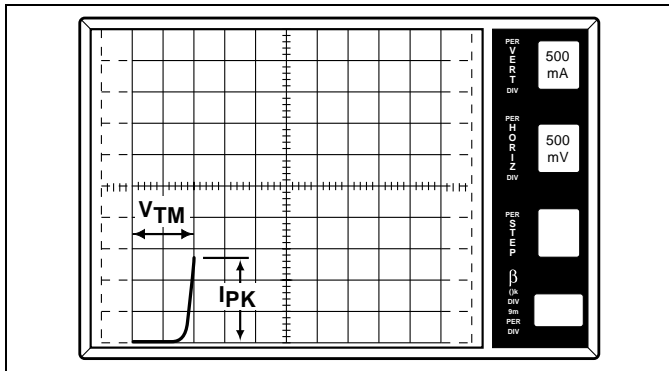

Figure 19.23  $V_{TM}$  (Forward) is equal to 950mV at  $I_{PK}$  equal to 1.4 amps

## Procedure 10: $V_{TM}$ (Reverse)

To measure the  $V_{TM}$  (Reverse) parameter:

1. Set *Polarity* to (-).
2. Repeat Procedure 8 to measure  $V_{TM}$ (Reverse).

## DIACS

Diacs are voltage breakdown switches used to “trigger-on” triacs and non-sensitive SCRs in phase control circuits.

Note: Diacs are bi-directional devices and can be connected in either direction.

To connect the Diac:

1. Connect one side of the diac to the *Collector Terminal* (C).
2. Connect other side of the diac to the *Emitter Terminal* (E).

To begin testing, perform the following procedures.

### Procedure 1: Curve Tracer Setup

To set the curve tracer and begin testing:

1. Set *Collector Voltage Supply Range* to 75 Max Peak volts.
2. Set *Horizontal* knob to sufficient scale to allow viewing of trace at the required voltage level (10 to 20 volts/DIV depending on device being tested).
3. Set *Vertical* knob to 50 microamps/DIV.
4. Set *Polarity* to AC.
5. Set *Mode* to Norm.
6. Set *Power Dissipation* to 0.5 watts.
7. Set *Terminal Selector* to Emitter Grounded-Open Base.

### Procedure 2: $V_{BO}$

To measure the  $V_{BO}$  parameter:

1. Set *Left-Right Terminal Jack Selector* to correspond with the location of the test fixture.
2. Increase *Variable Collector Supply Voltage* until breakover occurs. (See Figure 19.24.) The voltage at which current begins to flow and voltage does not increase is the  $V_{BO}$  value.

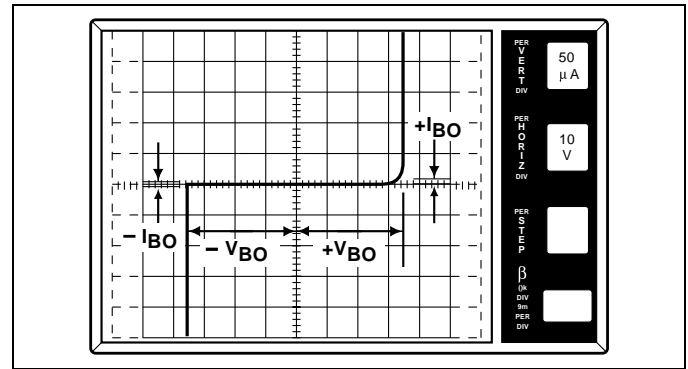

Figure 19.24 (+) $V_{BO}$  is equal to 35 volts; (-) $V_{BO}$  is equal to 36 volts; ( $\pm$ ) $I_{BO}$  is less than 15 $\mu$ A; (-) $I_{BO}$  is less than 10 $\mu$ A and cannot easily be read

### Procedure 3: $I_{BO}$

To measure the  $I_{BO}$  parameter, at the  $V_{BO}$  point, measure the amount of device current just before the device reaches the breakover mode. The measured current at this point is the  $I_{BO}$  value.

Note: If  $I_{BO}$  is less than 10 microamps, the current cannot readily be seen on the curve tracer.

### Procedure 4: $\Delta V_{BO}$ (Voltage Breakover Symmetry)

To measure the  $\Delta V_{BO}$  (Voltage Breakover Symmetry) parameter:

1. Measure positive and negative values of  $V_{BO}$  per above.
2. Subtract the absolute value of  $V_{BO}$  (-) from  $V_{BO}$ (+).

The absolute value of the result is:

$$\Delta V_{BO}: \Delta V_{BO} = [ | +V_{BO} | - | -V_{BO} | ]$$

## MODEL 577 CURVE TRACER PROCEDURE NOTES

The curve tracer procedure was actually written for the TEKTRONIX Model 576 curve tracer. On the Model 576 curve tracer, there are separate controls for polarity (AC,+,-) and mode (Norm, DC, Leakage), whereas the Model 577 has only a polarity control. However, if the following guidelines are followed, the Model 577 can be used just as easily.

Model 576	Model 577
If using <i>Leakage</i> mode along with polarity setting of +(NPN) and -(PNP), [vertical scale divided by one thousand],	set <i>Collector Supply Polarity</i> to either +DC or -DC, depending on polarity setting specified in the procedure. The vertical scale is read directly from the scale on the control knob.
If using <i>DC</i> mode along with either +(NPN) or -(PNP) polarity,	set <i>Collector Supply Polarity</i> to either +DC or -DC depending on polarity specified.
If using <i>Norm</i> mode along with either +(NPN) or -(PNP) polarity,	set <i>Collector Supply Polarity</i> to either +(NPN) or -(PNP) per specified procedure.
If using <i>Norm</i> mode with AC polarity,	set <i>Collector Supply Polarity</i> to AC.

Another minor difference between the two models is in setting the *Step/Offset Polarity*. The polarity is inverted when the button is depressed on the Model 576 curve tracer. The Model 577 is opposite — the *Step/Offset Polarity* is "inverted" when the button is extended and "Normal" when the button is depressed. The *Step/Offset Polarity* is used only when measuring  $I_{GT}$  and  $V_{GT}$  of triacs and QUADRACs in Quadrants I-IV.

Also, the *Variable Collector Supply Voltage Range* and *Power Dissipation* controls have different scales between the two different models, as shown in the following table:

Model 576	Model 577
If power dissipation is 0.1 watts,	set at 0.15 watts.
If power dissipation is 0.5 watts,	set at 0.6 watts.
If power dissipation is 2.2 watts,	set at 2.3 watts.
If power dissipation is 10 watts,	set at 9 watts.
If power dissipation is 50 watts,	set at 30 watts.
If power dissipation is 220 watts,	set at 100 watts.

Although the maximum power setting on the Model 576 curve tracer is 220 watts, versus 100 watts for the Model 577, the maximum collector current available is approximately the same. This is due to the minimum voltage range on the Model 577 being 6.5 volts vs 15 volts for the Model 576 curve tracer. The following table shows the correct *Collector Voltage Supply Range* settings:

Model 576	Model 577
If voltage range is 15 volts,	set at either 6.5 volts or 25 volts, depending on parameter being tested. Set at 6.5 volts when measuring $V_{TM}$ (to allow maximum collector current) and set at 25 volts when measuring $I_{GT}$ and $V_{GT}$ .
If voltage range is 75 volts,	set at 100 volts.
If voltage range is 1500 volts,	set at 1600 volts.

# Testing Teccor Semiconductor Devices Using Curve Tracers

## MODEL 370 CURVE TRACER PROCEDURE NOTES

The curve tracer procedure was actually written for the TEKTRONIX Model 576 curve tracer. Also, the *Variable Collector Supply Voltage Range* and *Power Dissipation* controls have different scales between the two different models. However, if the following guidelines are followed, the Model 370 can be used just as easily.

Model 576	Model 370
If power dissipation is 0.1 watts,	set at 0.08 watts.
If power dissipation is 0.5 watts,	set at 0.4 watts.
If power dissipation is 2.2 watts,	set at 2.0 watts.
If power dissipation is 10 watts,	set at 10 watts.
If power dissipation is 50 watts,	set at 50 watts.
If power dissipation is 220 watts,	set at 220 watts.

Although the maximum power setting on the Model 370 curve tracer is 200 watts, the maximum collector voltage available is only 400 volts at 220 watts. The following table shows the correct *Collector Voltage Supply Range* settings:

Model 576	Model 370
If voltage range is 15 volts,	set at 16 volts.
If voltage range is 75 volts,	set at 80 volts.
If voltage range is 350 volts,	set at 400 volts.
If voltage range is 1500 volts,	set at 2000 volts.

The following table shows the different terminal selector (configuration on 370) knob settings between the two models:

Model 576	Model 370
If Step generator (base) is emitter grounded,	then, Base Step generator is emitter common.
If Emitter grounded is open base,	then, Base open is emitter common.

## INSTRUCTIONS FOR WIRING KELVIN SOCKET

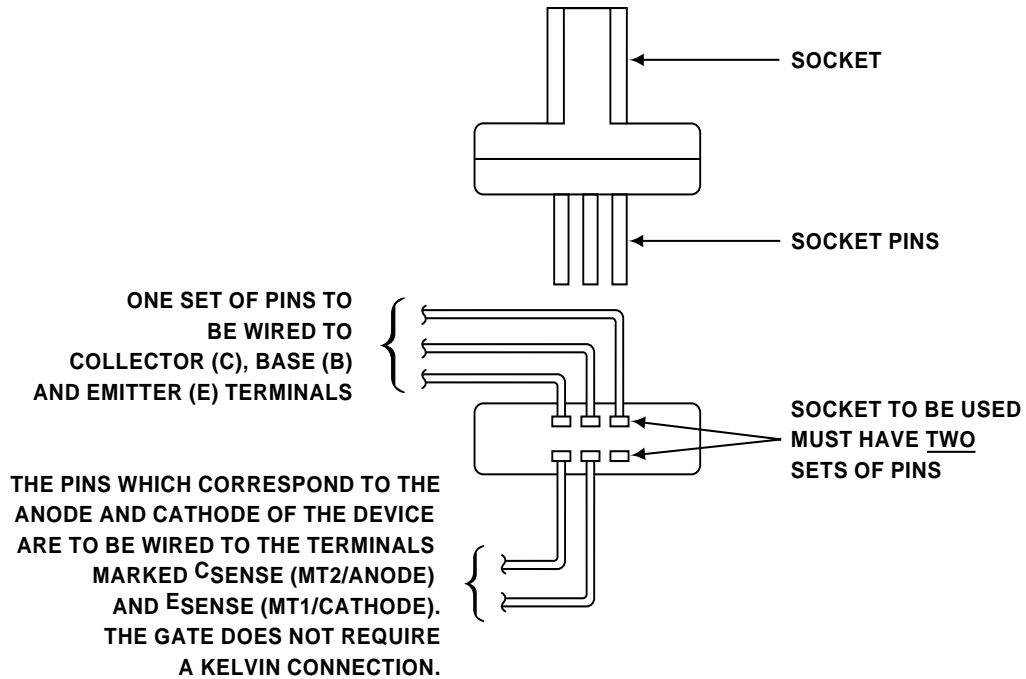

# Testing Teccor Semiconductor Devices Using Curve Tracers

## TEST SET-UP CHART, TYPE 576

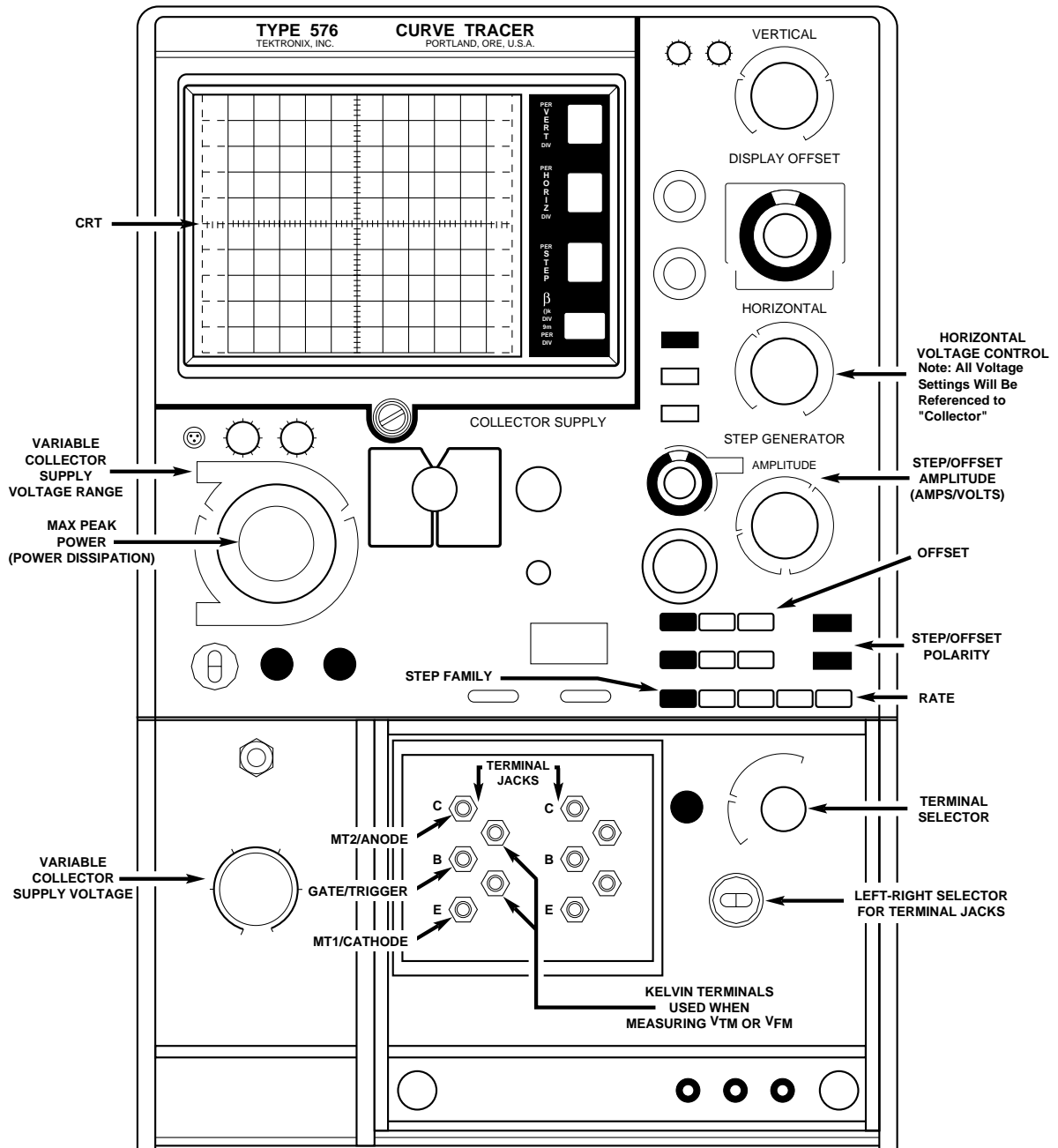

# TEST SET-UP CHART, TYPE 577

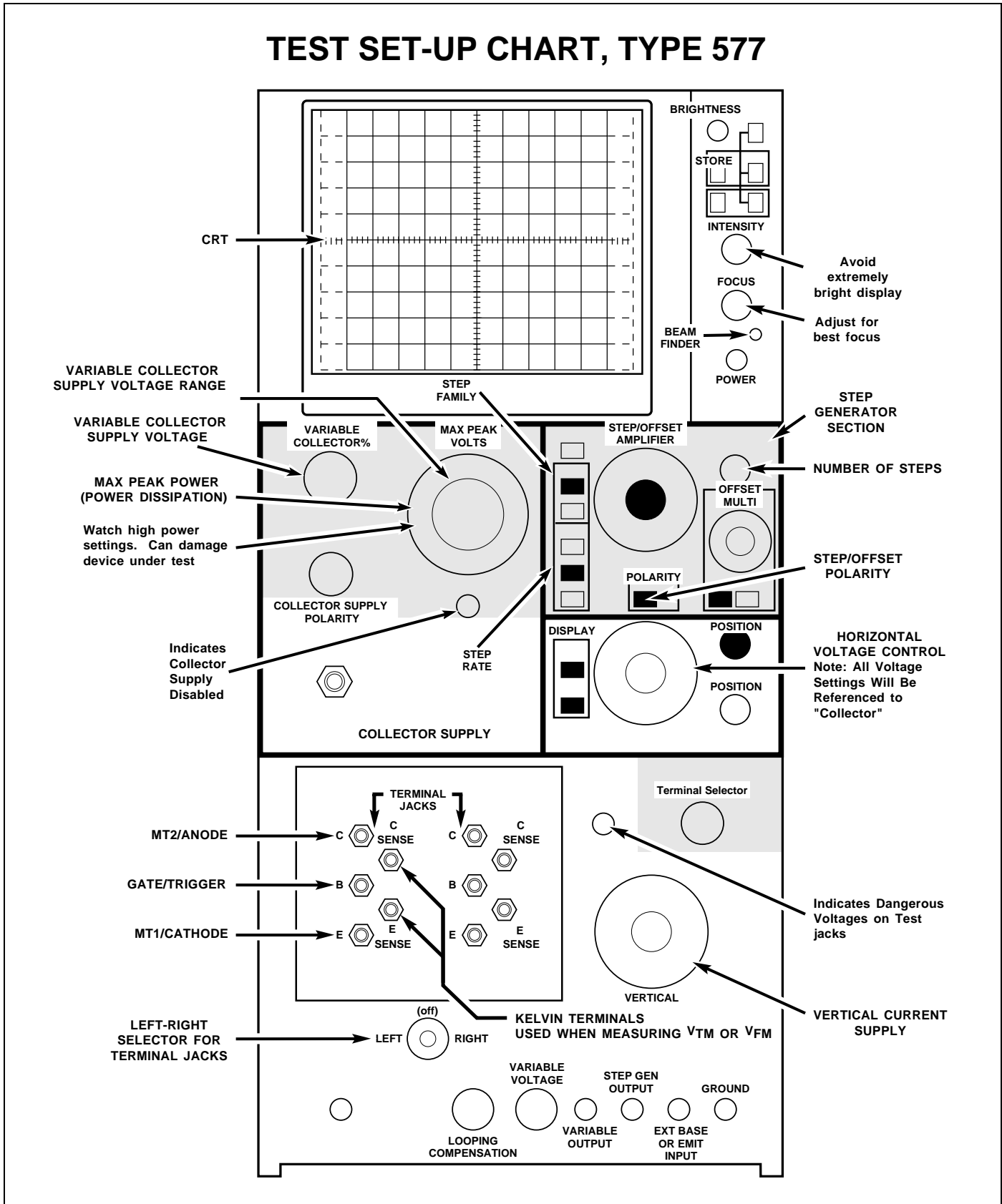

# Testing Teccor Semiconductor Devices Using Curve Tracers

## TEST SET-UP CHART, TYPE 370

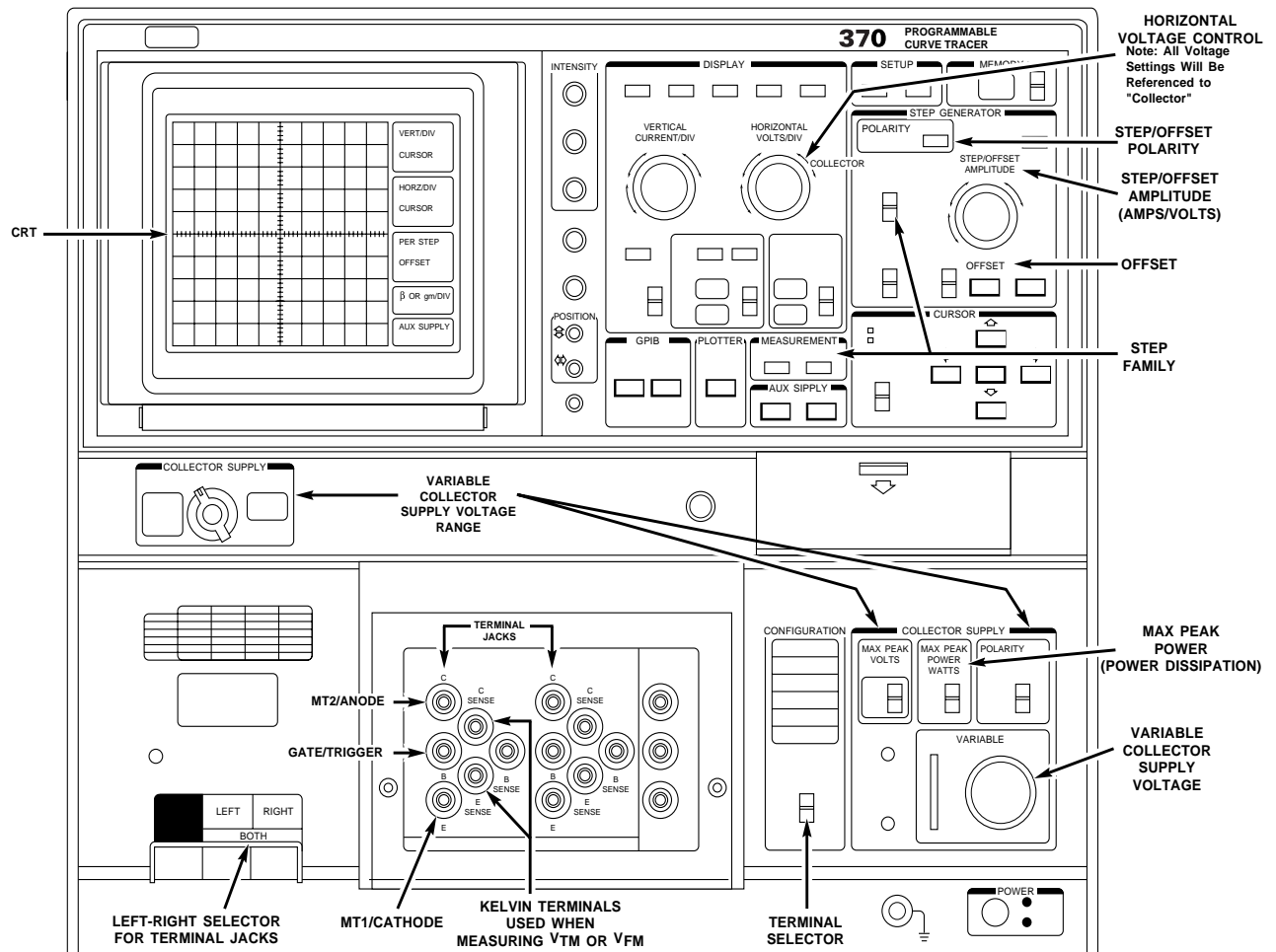

# Notes

---